

DATE:  
 QUOTE ID:  
 PROJECT:  
 LOCATION:

SEND TO:  
 ATTENTION:  
 ALUM. FINISH:

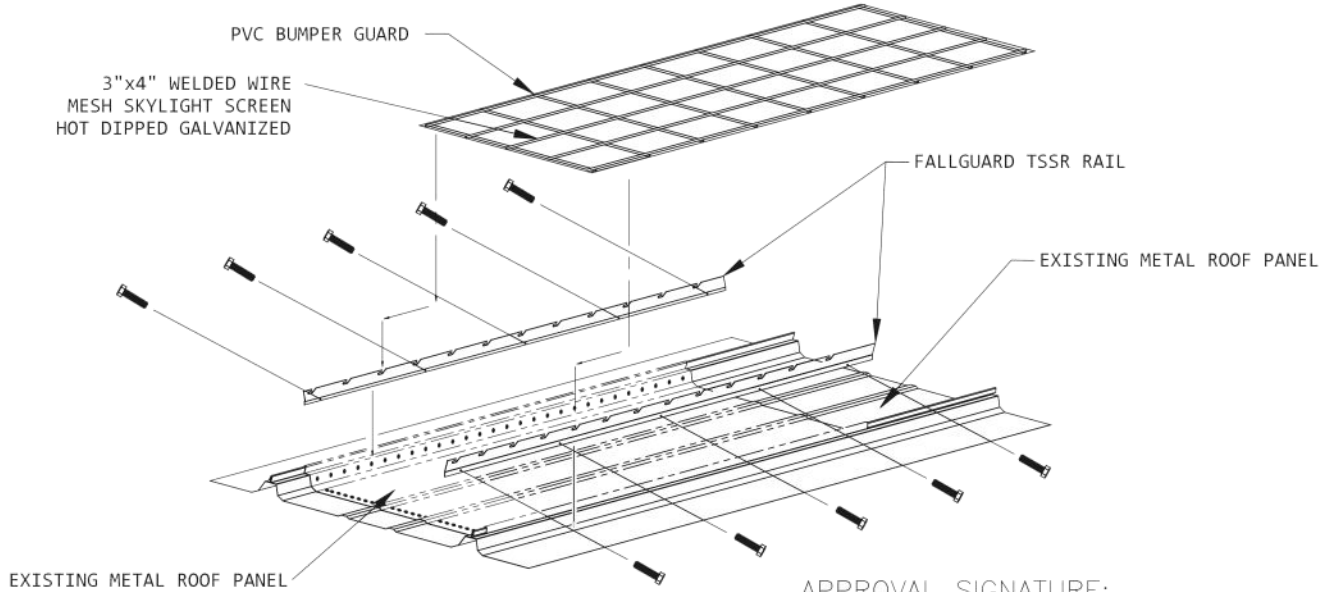

APPROVAL SIGNATURE: \_\_\_\_\_  
 APPROVAL DATE: \_\_\_\_\_

MODEL NO.	WIDTH	LENGTH	PANEL TYPE	QUANTITY	NOTES

